



Alabaster Alba

The Alabaster Alba Wall Lamp is conceived as an architectural composition of natural Spanish alabaster and solid copper, designed to bring material warmth and sculptural rhythm to refined interiors. Five hand-carved alabaster spheres create a balanced vertical arrangement that diffuses light with exceptional softness, transforming walls into luminous architectural features rather than decorative elements.



ARCHITECTURAL PRODUCT SPECIFICATION

Technical Specifications:

- SKU: HDLS#AlabasterAlba
- Overall Dimensions: H 55 cm × W 30 cm (H 21.6" × W 11.8")
- Weight: 10 kg (22 lbs)
- Light Sources: 5 illuminated alabaster spheres
- Lamp Type: G9 LED
- Dimming: Compatible with dimmable G9 LED systems
- Material – Diffusers: Hand-carved Spanish alabaster
- Material – Structure: Solid copper
- Alabaster Sphere Diameter: Ø10 cm (4") each
- Finish: Brushed Brass
- Voltage Compatibility: 110–120V / 220–240V
- Installation: Hardwired wall installation
- Certifications: UKCA, CE, UL, CSA, RoHS

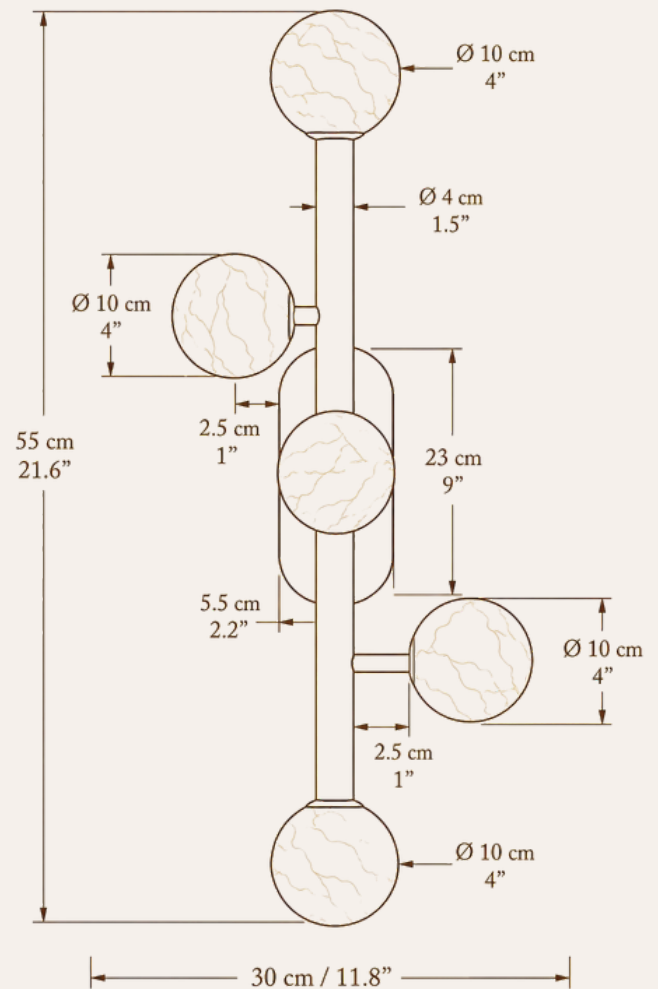

HDLS Lighting Ltd

45 Albemarle Street, Mayfair
London, W1S 4JL GB

info@homedecorlightstore.com

+44 7502 590333

www.homedecorlightstore.com



ARCHITECTURAL PRODUCT SPECIFICATION



Materials

- Hand-carved Spanish alabaster spheres
- Solid copper structural framework
- Premium architectural-grade metal components
- Natural stone diffusers with unique veining patterns

Craftsmanship

Each alabaster sphere is individually carved and hand-finished from natural Spanish alabaster selected for its translucency and organic character. Variations in veining, colour, and mineral composition ensure every fixture is entirely unique.

Lighting

Five illuminated alabaster spheres softly diffuse light through the natural stone, creating a warm ambient glow that enhances architectural surfaces while maintaining visual comfort and atmosphere.

Installation

Designed for hardwired wall installation in luxury residential and hospitality environments. Professional installation is recommended.

Certifications:

- UKCA
- CE
- UL
- CSA
- RoHS

Warranty

18-Month Manufacturer Warranty

Lead Time

4–6 Weeks Standard Production Lead Time

HDLS Lighting Ltd

45 Albemarle Street, Mayfair
London, W1S 4JL GB

info@homedecorlightstore.com
+44 7502 590333

www.homedecorlightstore.com



ARCHITECTURAL PRODUCT SPECIFICATION



Alabaster Alba demonstrates the enduring appeal of authentic materials shaped through considered craftsmanship. Combining hand-carved Spanish alabaster with solid copper construction, it provides both illumination and architectural presence, making it well-suited to luxury residences, boutique hospitality projects, private suites, corridors, dressing rooms, and refined bathroom environments where atmosphere and material authenticity are paramount.

HDLS Lighting Ltd

45 Albemarle Street, Mayfair
London, W1S 4JL GB

info@homedecorlightstore.com
+44 7502 590333

www.homedecorlightstore.com